

- L:
 CBL-HFPD3SAB6CS-1m 1000mm±10mm
 CBL-HFPD3SAB6CS-2m 2000mm±20mm
 CBL-HFPD3SAB6CS-3m 3000mm±20mm
 CBL-HFPD3SAB6CS-4m 4000mm±30mm
 CBL-HFPD3SAB6CS-5m 5000mm±30mm

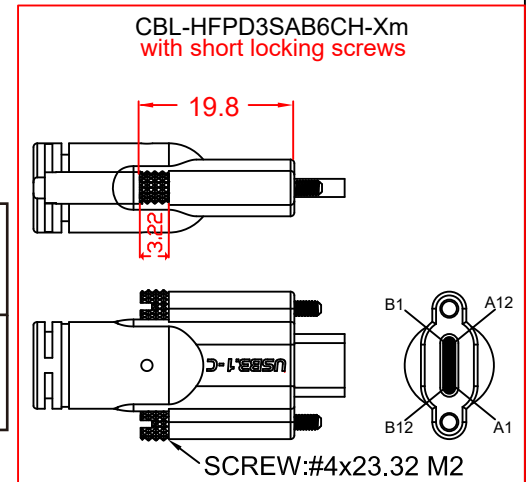
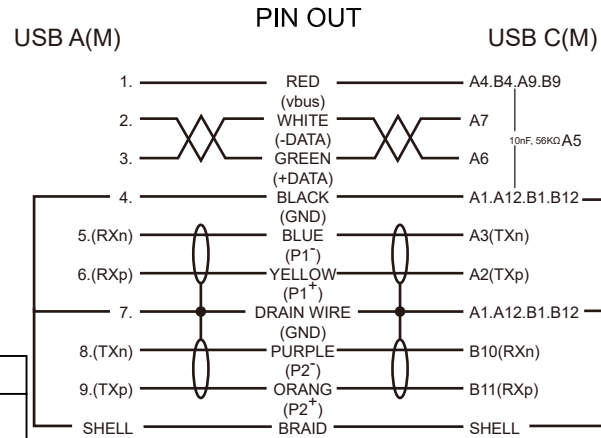

No	MATERIALS LIST:
1.	CABLE: 3 x (2 x 24 AWG)ST + 2 x 22 AWG O.D.:8.8mm COLOR:RED LILAC
2.	CONNECTOR:USB 3.0 A/M, 9P, BLUE INSULATOR SOLDER TYPE, NICKEL PLATED SHELL
3.	CONNECTOR:USB 3.1 TYPE-C, MALE, NICKEL PLATED SHELL
4.	PVC MOLDED HOUSING, BLACK COLOR
5.	SCREW:#4x33 M2

Jargy part no.	Client part no.	Approved	SCALE	UNIT
CBL-HFPD3SAB6CS-xm				mm
Drawing Name		Drawn	Date	REV.
USB 3.1 GEN 1 A to C Cable M/M				1.0

Mobile Computing JARGY

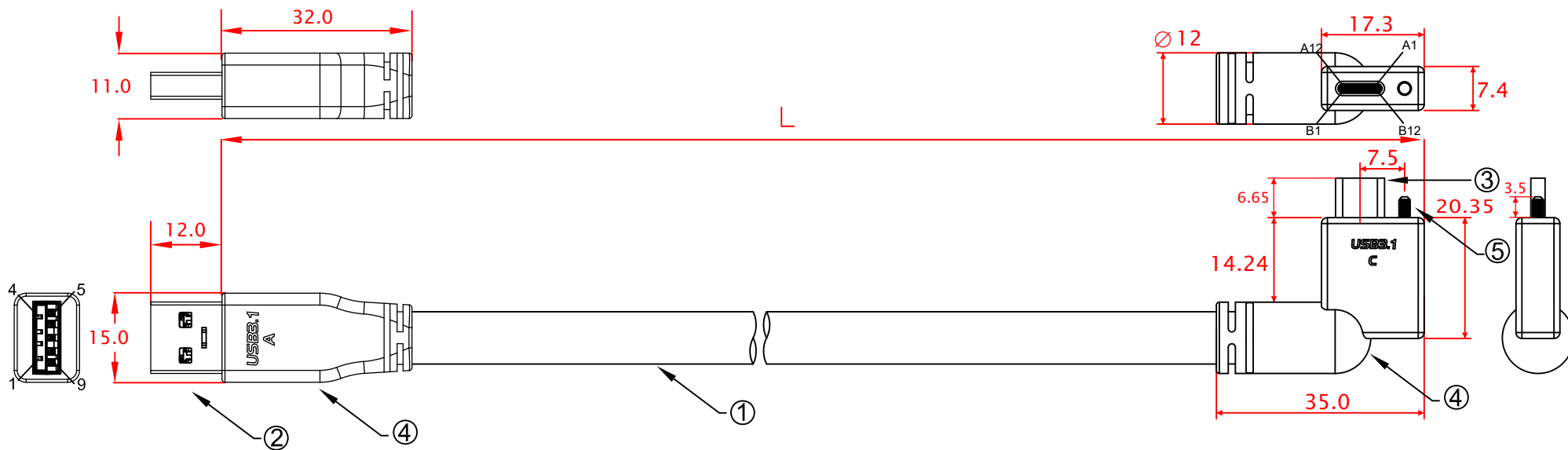

- L:
- CBL-HFPD3SAB6CH-1mLRA 1000mm±10mm
 - CBL-HFPD3SAB6CH-2mLRA 2000mm±20mm
 - CBL-HFPD3SAB6CH-3mLRA 3000mm±20mm
 - CBL-HFPD3SAB6CH-4mLRA 4000mm±30mm
 - CBL-HFPD3SAB6CH-5mLRA 5000mm±30mm

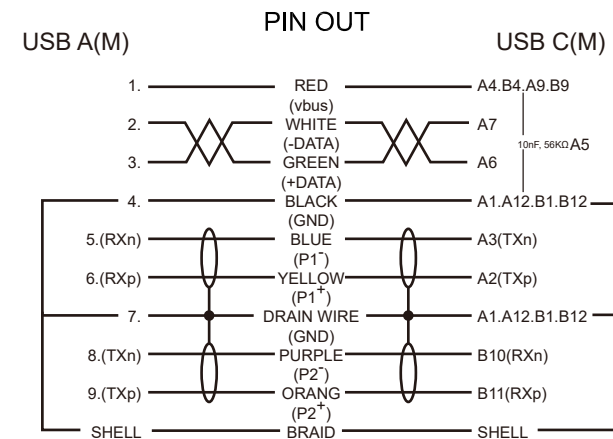

No	MATERIALS LIST:
1.	CABLE: 3 x (2 x 24 AWG)ST + 2 x 22 AWG O.D.:8.8mm COLOR:RED LILAC
2.	CONNECTOR:USB 3.0 A/M, 9P, BLUE INSULATOR SOLDER TYPE, NICKEL PLATED SHELL
3.	CONNECTOR:USB 3.1 TYPE-C, MALE, NICKEL PLATED SHELL
4.	PVC MOLDED HOUSING, BLACK COLOR
5.	SCREW:#4x23.32 M2

Jargy part no.	Client part no.	Approved	SCALE	UNIT
CBL-HFPD3SAB6CH-xmLRA				mm
Drawing Name		Drawn	Date	REV.
USB 3.1 GEN 1 A to C Cable M/M				1.0

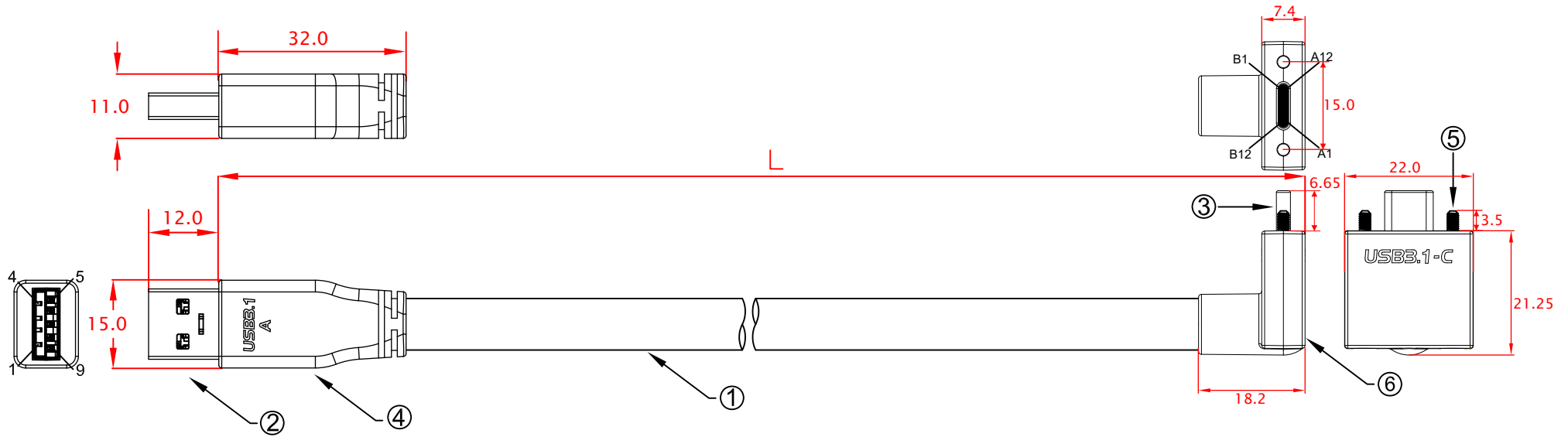

- L:
- CBL-HFPD3SAB6CH-1mUDA 1000mm±10mm
 - CBL-HFPD3SAB6CH-2mUDA 2000mm±20mm
 - CBL-HFPD3SAB6CH-3mUDA 3000mm±20mm
 - CBL-HFPD3SAB6CH-4mUDA 4000mm±30mm
 - CBL-HFPD3SAB6CH-5mUDA 5000mm±30mm

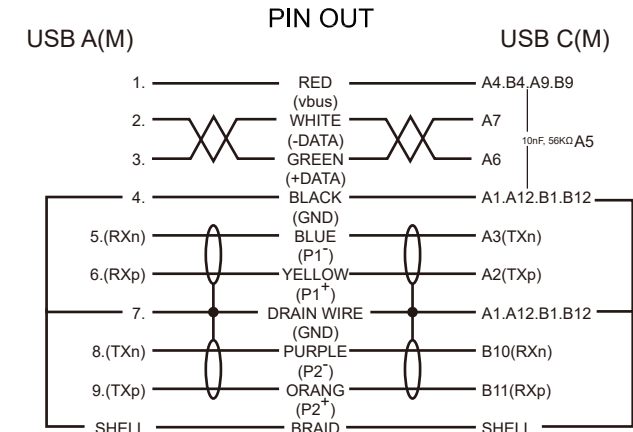

No	MATERIALS LIST:
1.	CABLE: 3 x (2 x 24 AWG)ST + 2 x 22 AWG O.D.:8.8mm COLOR:RED LILAC
2.	CONNECTOR:USB 3.0 A/M, 9P, BLUE INSULATOR SOLDER TYPE, NICKEL PLATED SHELL
3.	CONNECTOR:USB 3.1 TYPE-C, MALE, NICKEL PLATED SHELL
4.	PVC MOLDED HOUSING, BLACK COLOR
5.	SCREW:#4x23.32 M2
6.	ABS ASSEMBLY HOUSING, BLACK COLOR

Jargy part no.	Client part no.	Approved	SCALE	UNIT
CBL-HFPD3SAB6CH-xmUDA				mm
Drawing Name		Drawn	Date	REV.
USB 3.1 GEN 1 A to C Cable M/M				1.0